

Bx – sistemi costruttivi e soluzioni di finitura**B6** basamenti e zoccolature in pietra concia a faccia vista

B6.1- calcare o travertino in conci sbozzati alla subbia

B6.2- calcare o travertino in conci squadrate

B6.3- basalto o travertino in lastre bocciardate

B6.4- calcare o pietra serena in conci bugnati

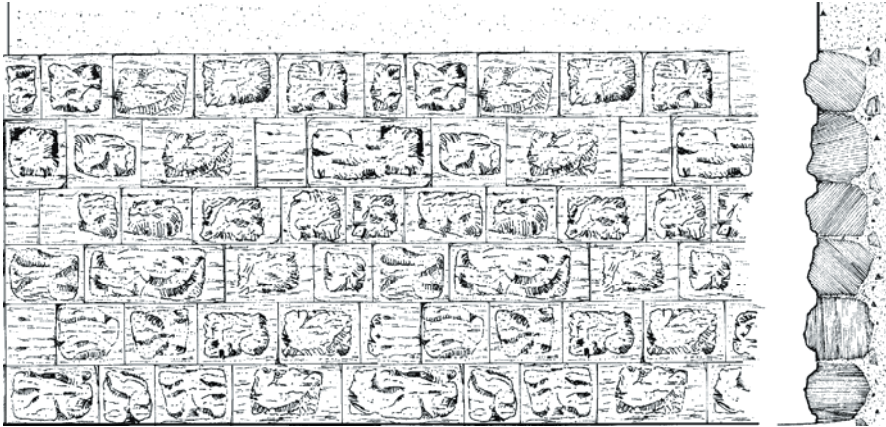

B6.1



B6.2

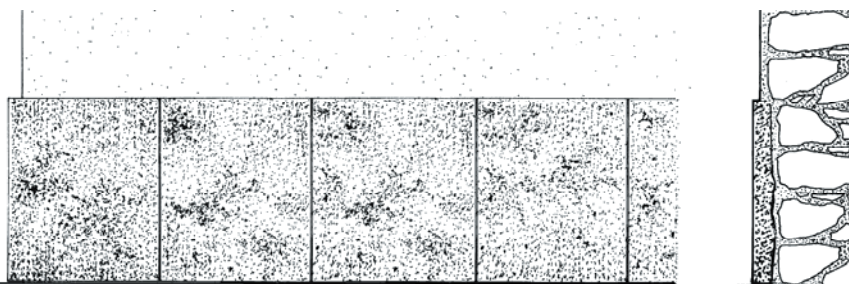

B6.3

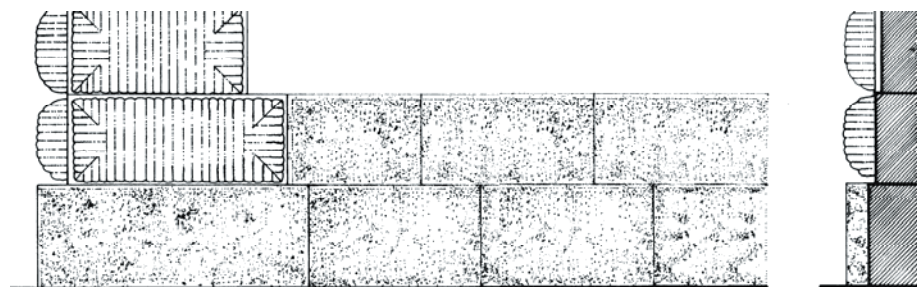

B6.4

B7 basamenti e zoccolature in laterizi a faccia vista

B7.1- zoccolo in mattoni da cortina o sagramati

B7.2- basamento in conci bugnati di mattoni sagramati



B7.1

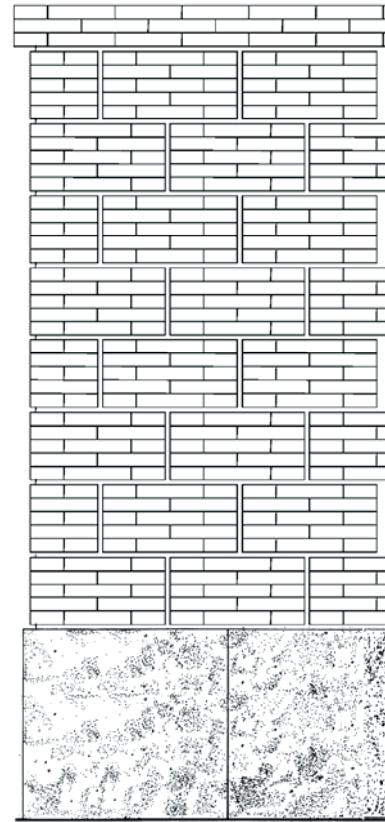

B7.2

B8 basamenti e zoccolature in muratura grezza non finita

B8.1- zoccolo in mattoni grezzi

B8.2- basamento in bugnato di mattoni grezzi

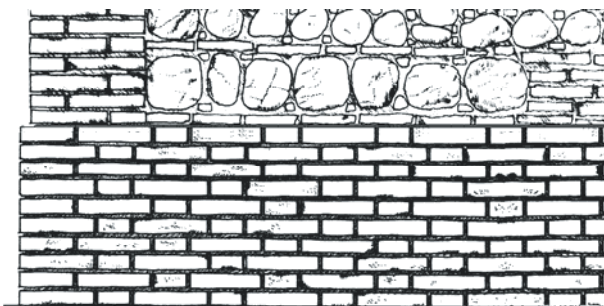

B8.1

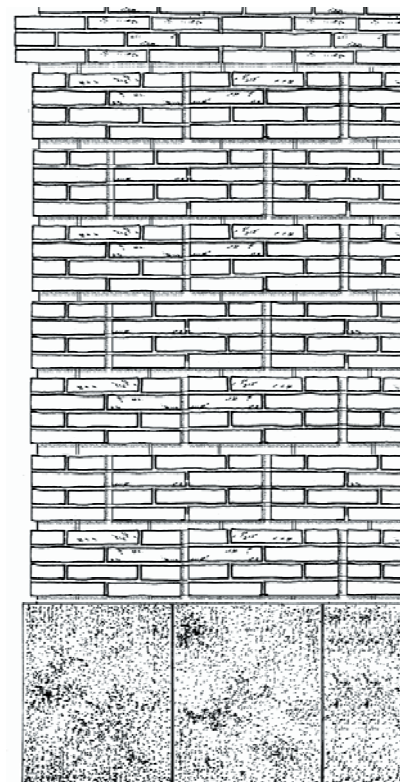

B8.2

B9 basamenti e zoccolature in muratura intonacata e dipinta

B9.1- basamento con bugnato intonacato

B9.2- zoccolo con bugnato intonacato

B9.3 - zoccolo con intonaco liscio

B9.4 - zoccolo con intonaco rustico “ai cretoncini”

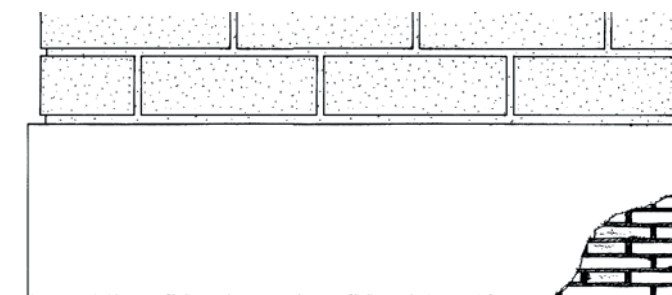

B9.3

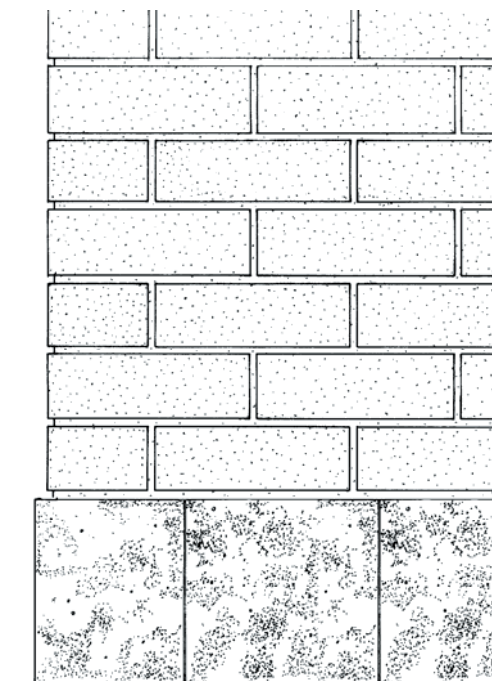

B9.1



B9.4

B10 - basamenti e zoccolature simulate pittoricamente a chiaroscuro

B10.1- zoccolo semplice dipinto

B10.2- basamento con bugnato simulato pittoricamente

B16 - modifiche recenti e soluzioni improprie

B16.3 - zoccolo liscio in lastre segate

B16.4 - intonaco liscio o bugnato decorticato indebitamente

B16.5 - mattoni stuccati impropriamente con malta di cemento

Dx - materiali e colori delle membrature**D2** - colori delle membrature intonacate

D2.1- bianco calcare o travertino

D2.2- grigio arenaria o basaltina

D2.3- giallo mattone

D2.4- colore proprio in tono su tono

Ax – tipi di membrature

A3 - membrature orizzontali

A3.1- cornice marcapiano su archetti pensili (beccatelli)

A3.2- cornice marcapiano

A3.3- trabeazione marcapiano

A3.4- cornice marcasoglia

A3.5- parapetto marcapiano

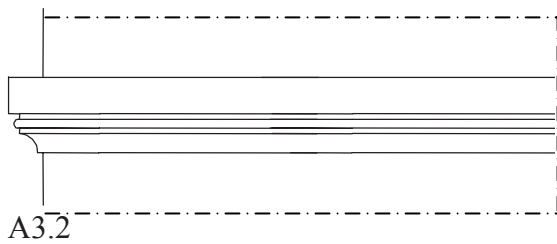

A3.2

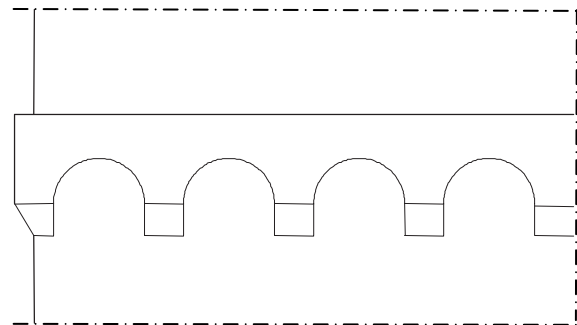

A3.1

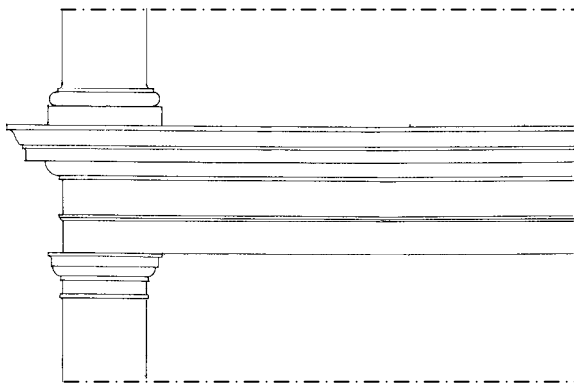

A3.3

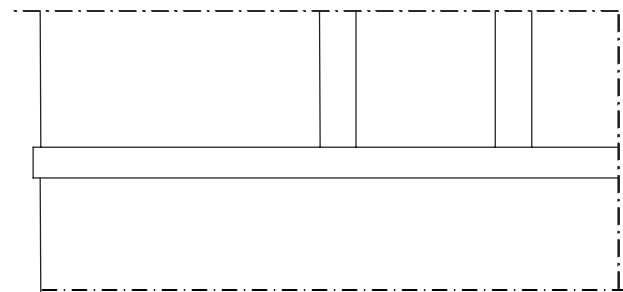

A3.4

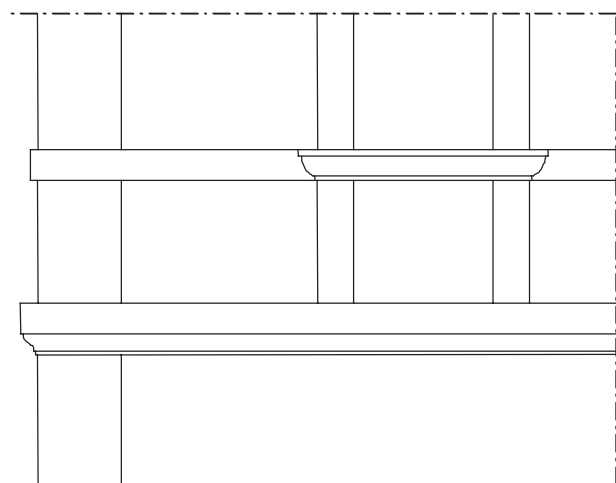

A3.5

A4 - membrature di coronamento

- A4.1- merlatura di coronamento a raso
- A4.2- cornice di coronamento su beccatelli
- A4.3- cornice sottogronda
- A4.4- trabeazione sottogronda
- A4.5- coronamento con parapetto ad attico
- A4.6- coronamento con fastigio a vela

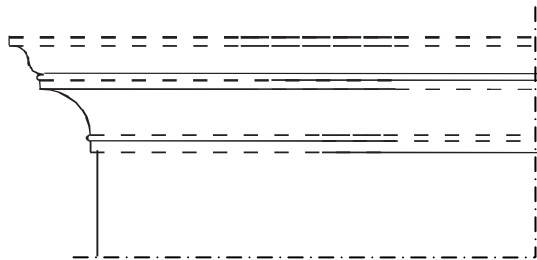

A4.3

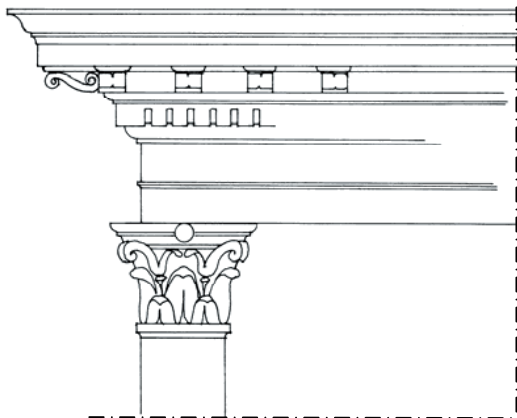

A4.4

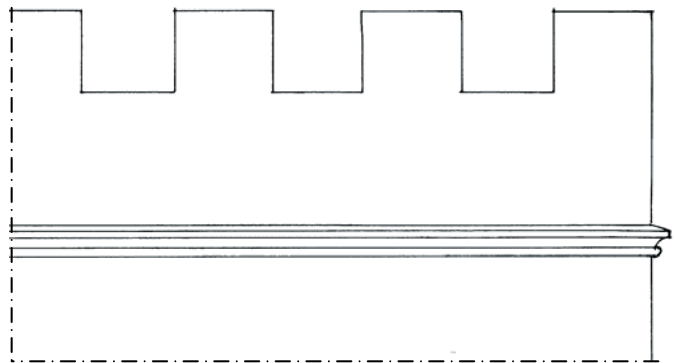

A4.1

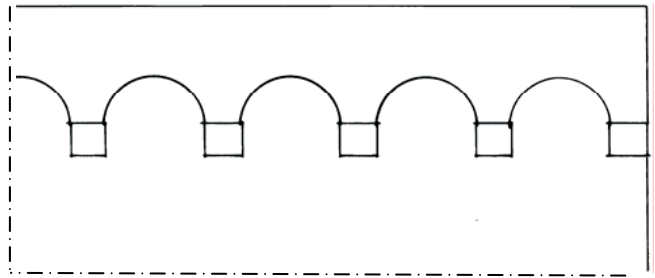

A4.2

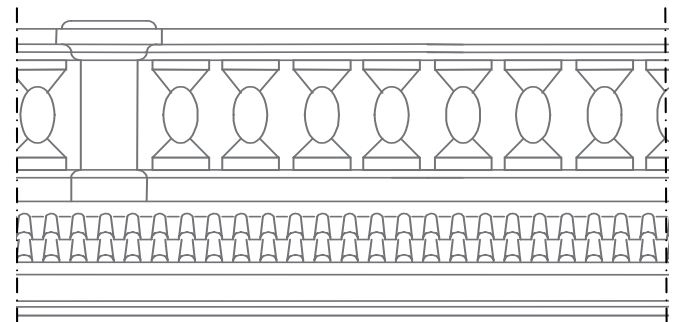

A4.5

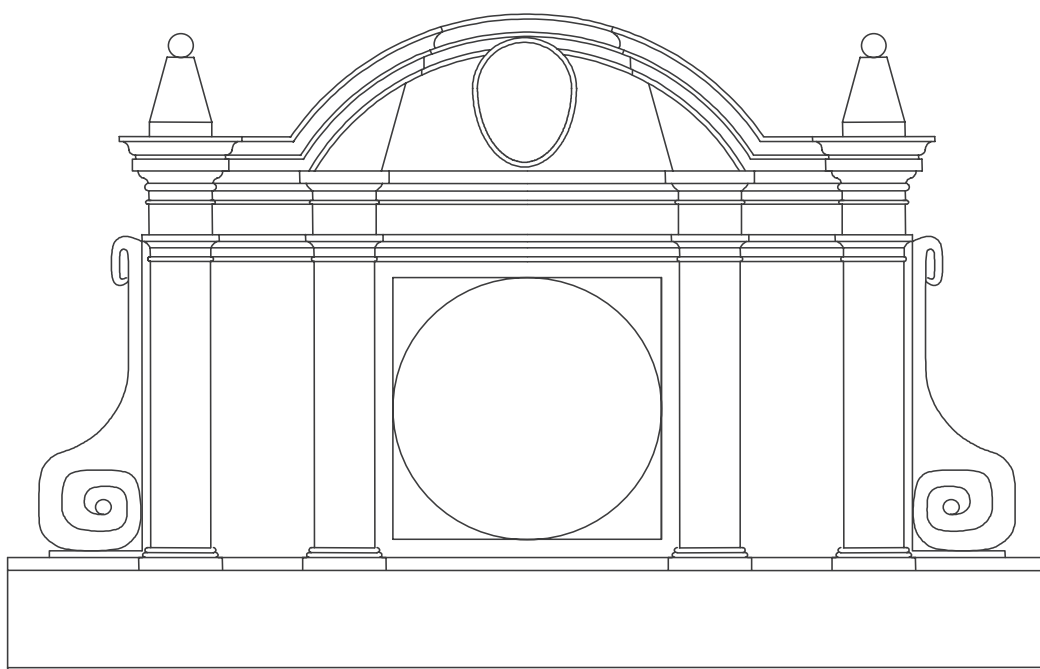

A4.6

Bx – sistemi costruttivi e soluzioni di finitura**B11 cornici e membrature orizzontali in conci di pietra a faccia vista**

B11.1- in conci squadrati

B11.2- in conci modanati

B11.3- su mensole

B11.4- con decorazioni intagliate

B11.5- su mensole e beccatelli

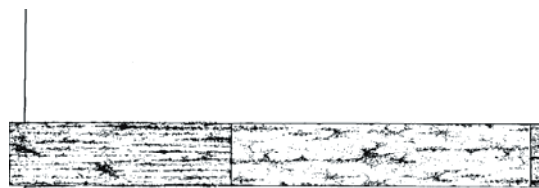
B11.6- con merlatura di coronamento
in conci squadrati o sbozzati

B11.1

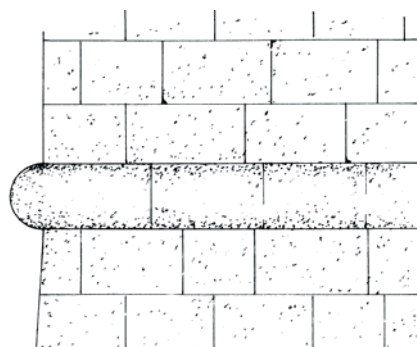
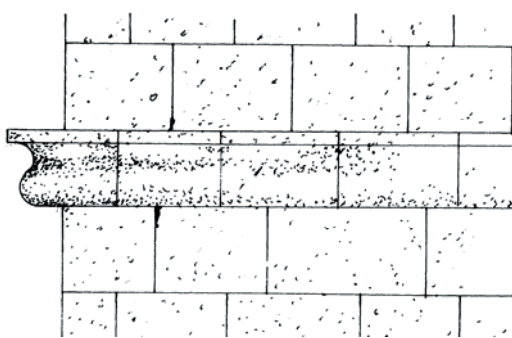
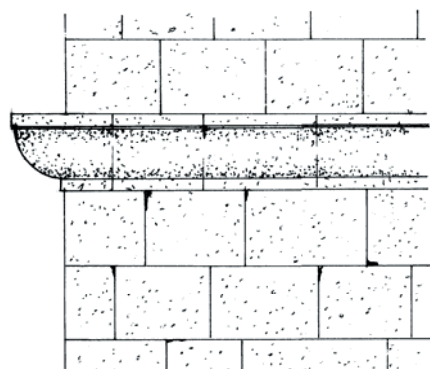
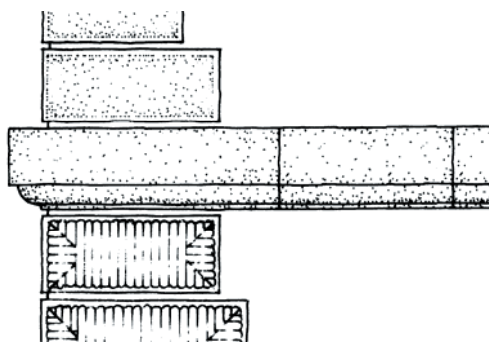
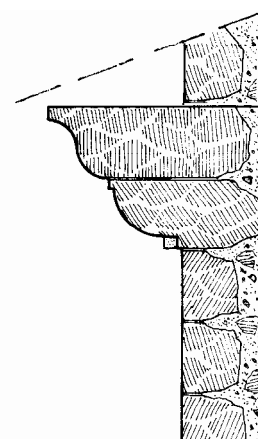
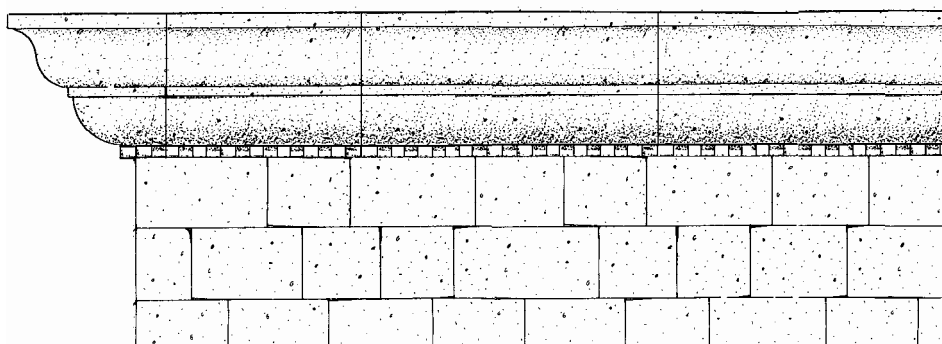

B11.2

Segue

B11 – cornici e membrature orizzontali in conci di pietra a faccia vista

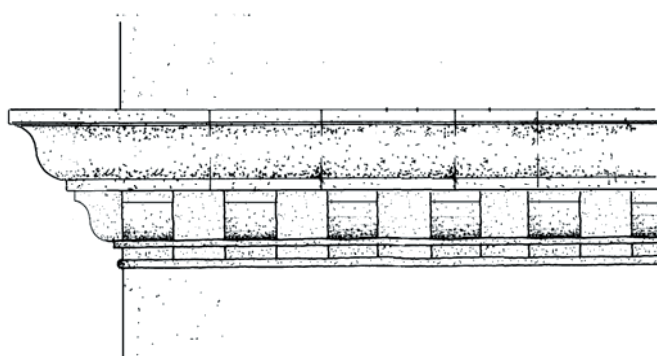
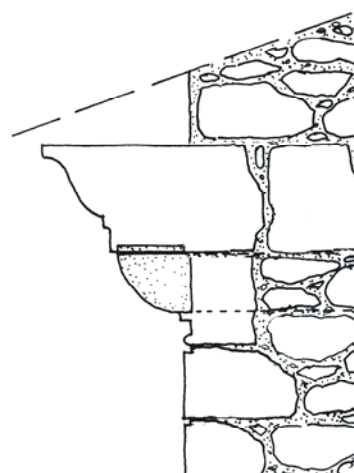
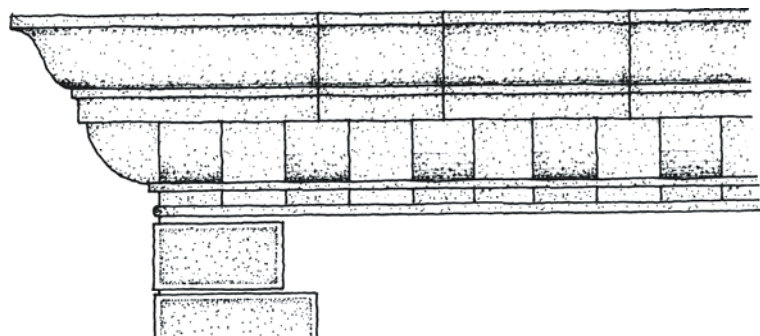

B11.3

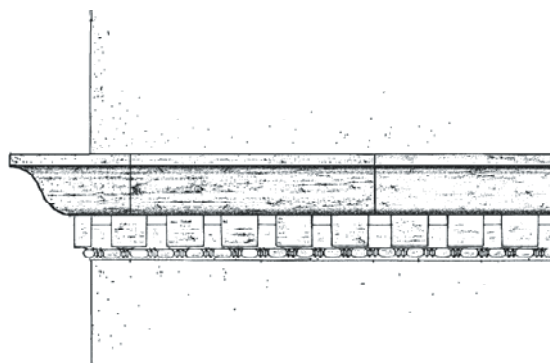
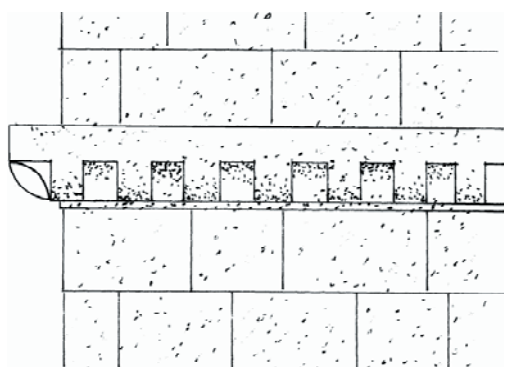
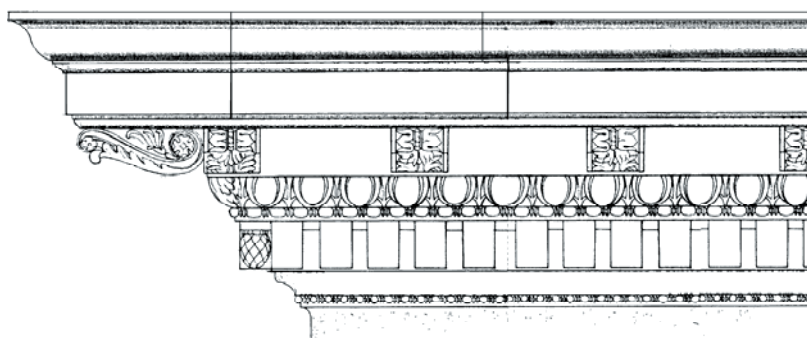

B11.4

Segue

B11 – cornici e membrature orizzontali in conci di pietra a faccia vista

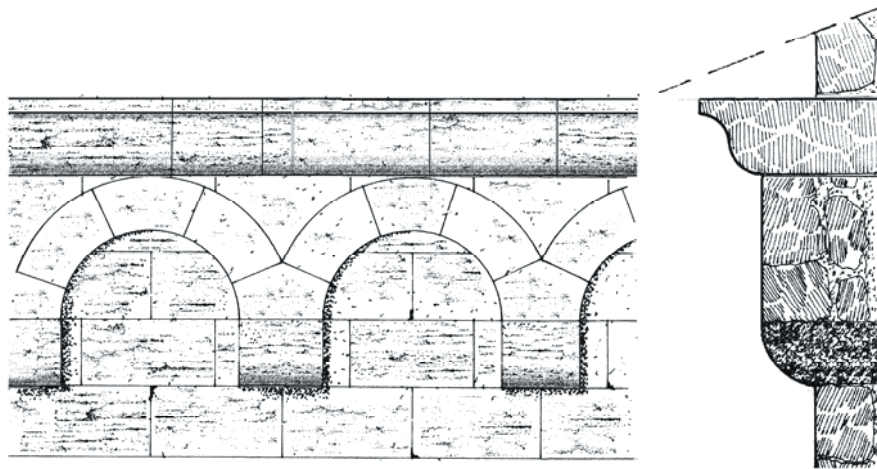

B11.5

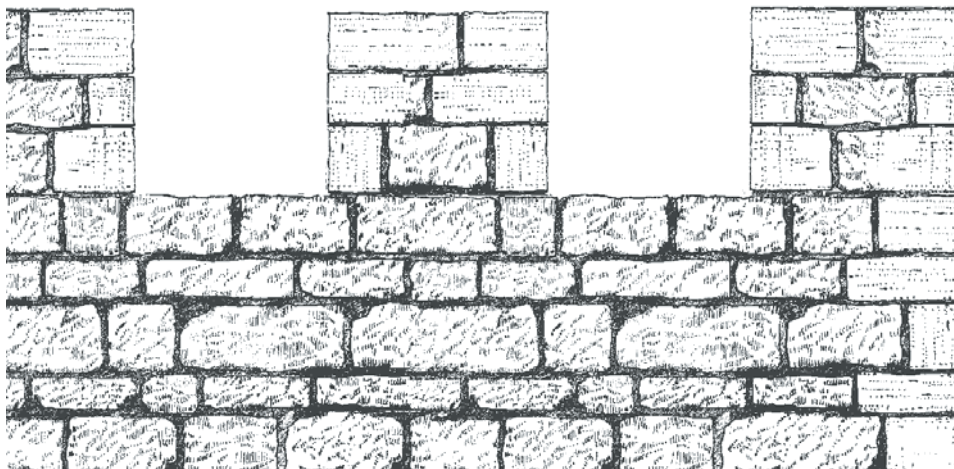

B11.6

Dx – materiali e colori delle membrature

D1 materiali lapidei a faccia vista

D1.1- pietra calcarea o travertino

D1.2- pietra arenaria o marnoso arenacea

D1.3- tufo vulcanico

D1.4- basaltina

Bx – sistemi costruttivi e soluzioni di finitura

B12 – cornici e membrature orizzontali in laterizi a faccia vista

B12.1- in mattoni ordinari o da cortina

B12.2- in mattoni sagomati

B12.3- su mensole e mattoni sfalsati

B12.4- su mensole e beccatelli

B12.5- con elementi in terracotta decorata

B12.6- con merlatura di coronamento

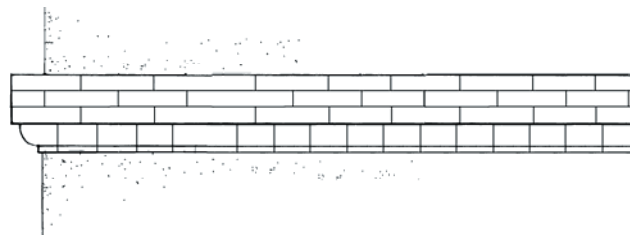

B12.1

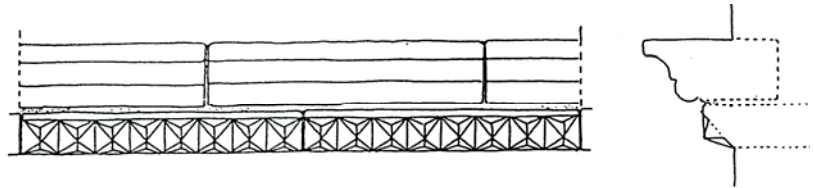

B12.2

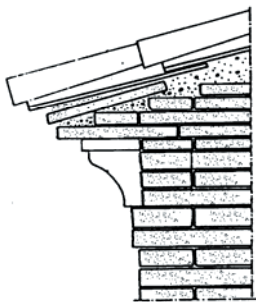

B12.3

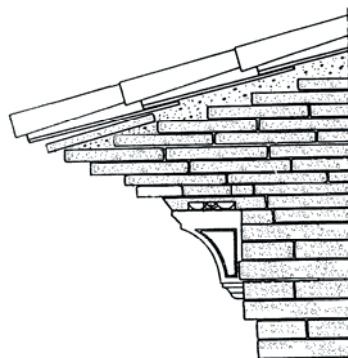

B12.3

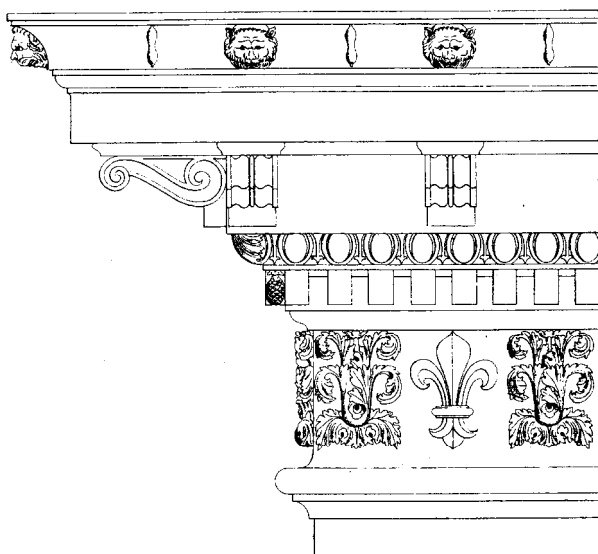

B12.5

B13 – cornici e membrature orizzontali in muratura grezza non finita

B13.1- in mattoni grezzi

B13.2- in tufo grezzo

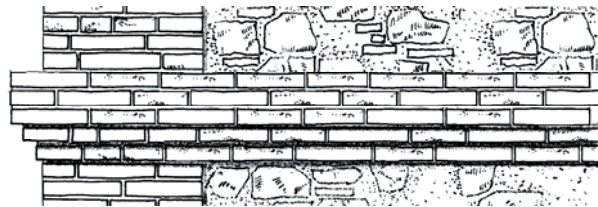
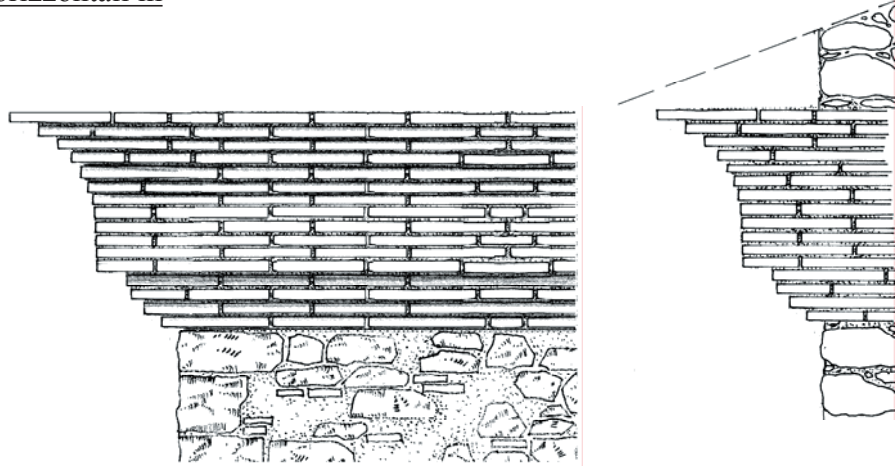

B13.1

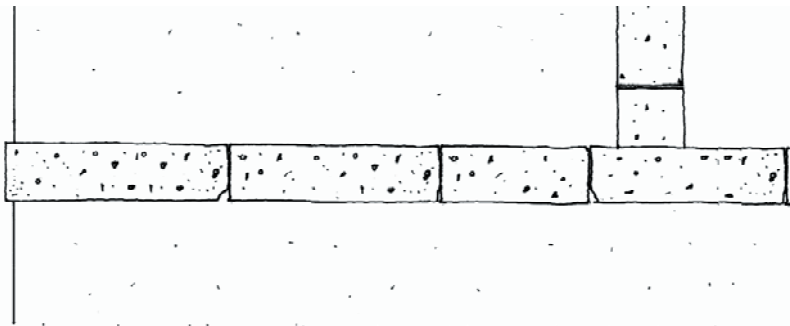
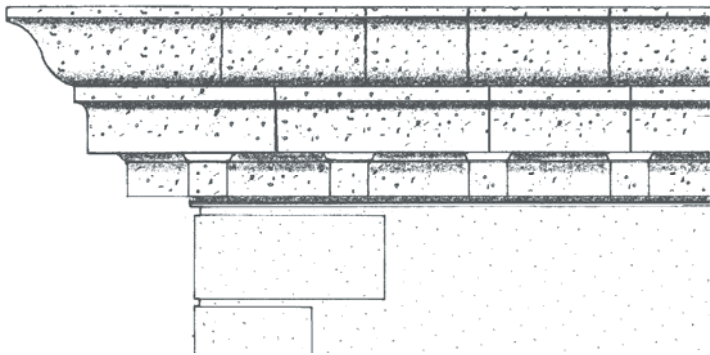

B13.2

B14 – cornici e membrature orizzontali in muratura intonacata e dipinta

B14.1- con sezioni squadrate

B14.2- con sezioni modanate

B14.3- con sezioni modanate su mensole

B14.4- con modanature decorate a stucco

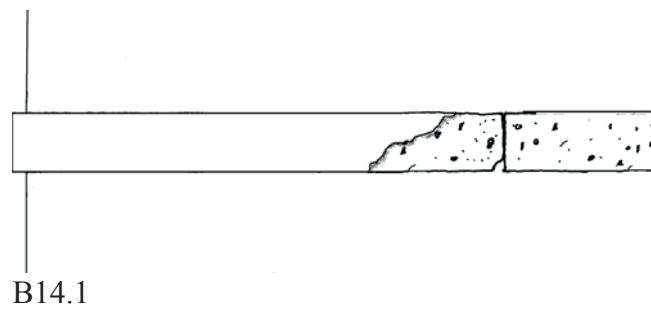

B14.2

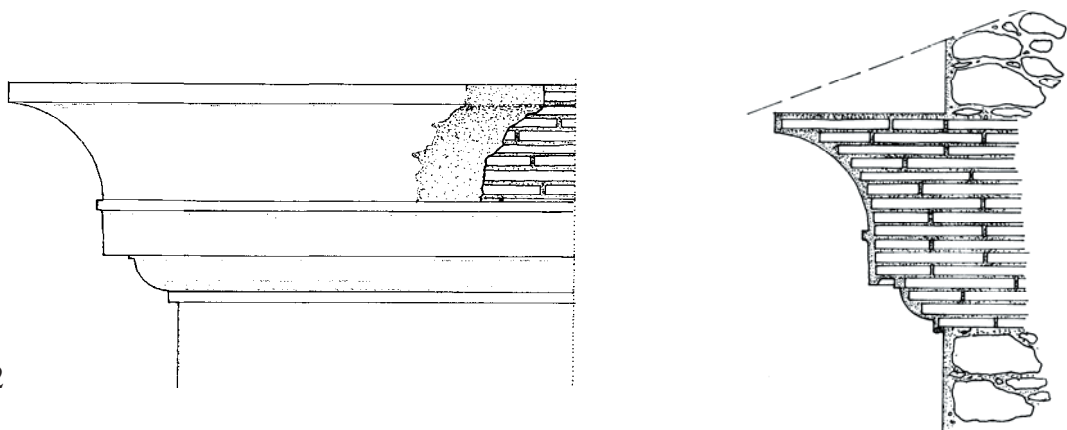

B14.3

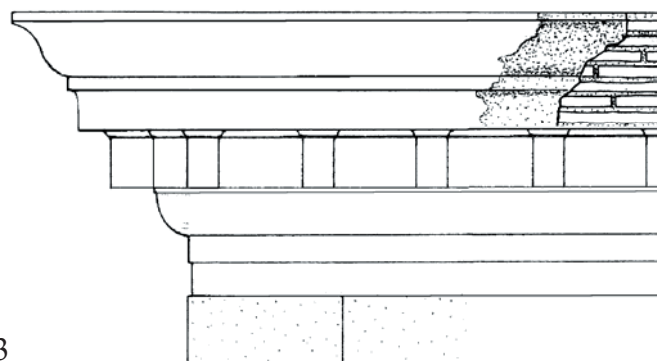

B14.4

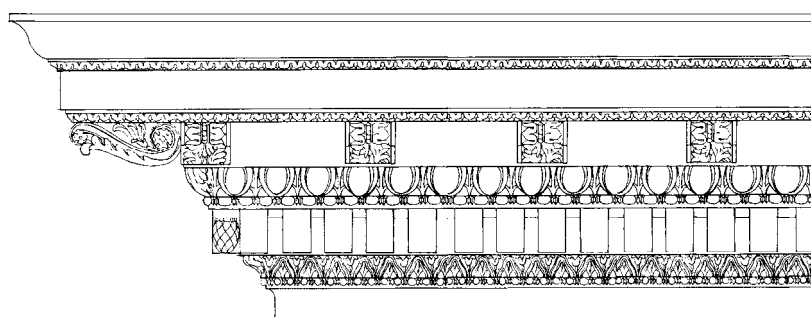

B15 – cornici e membrature orizzontali simulate pittoricamente a chiaroscuro (vedi B14)**B16 – modifiche recenti e soluzioni improprie**

B16.5- mattoni stuccati impropriamente con malta di cemento

B16.6- decorticazione di membrature orizzontali intonacate

B16.7 - ritinteggiatura con colori impropri di membrature orizzontali intonacate

Cx – soluzioni e varietà particolari**C2 modanature semplici**

C2.1- a sezione retta (fascia, listello, gocciolatoio)

C2.2- a sezione concava (guscio, cavetto, scozia)

C2.3- a sezione convessa (toro, tondino, ovolo, becco di civetta)

C2.4- a sezione concavo-convessa (gola diritta, gola rovescia)

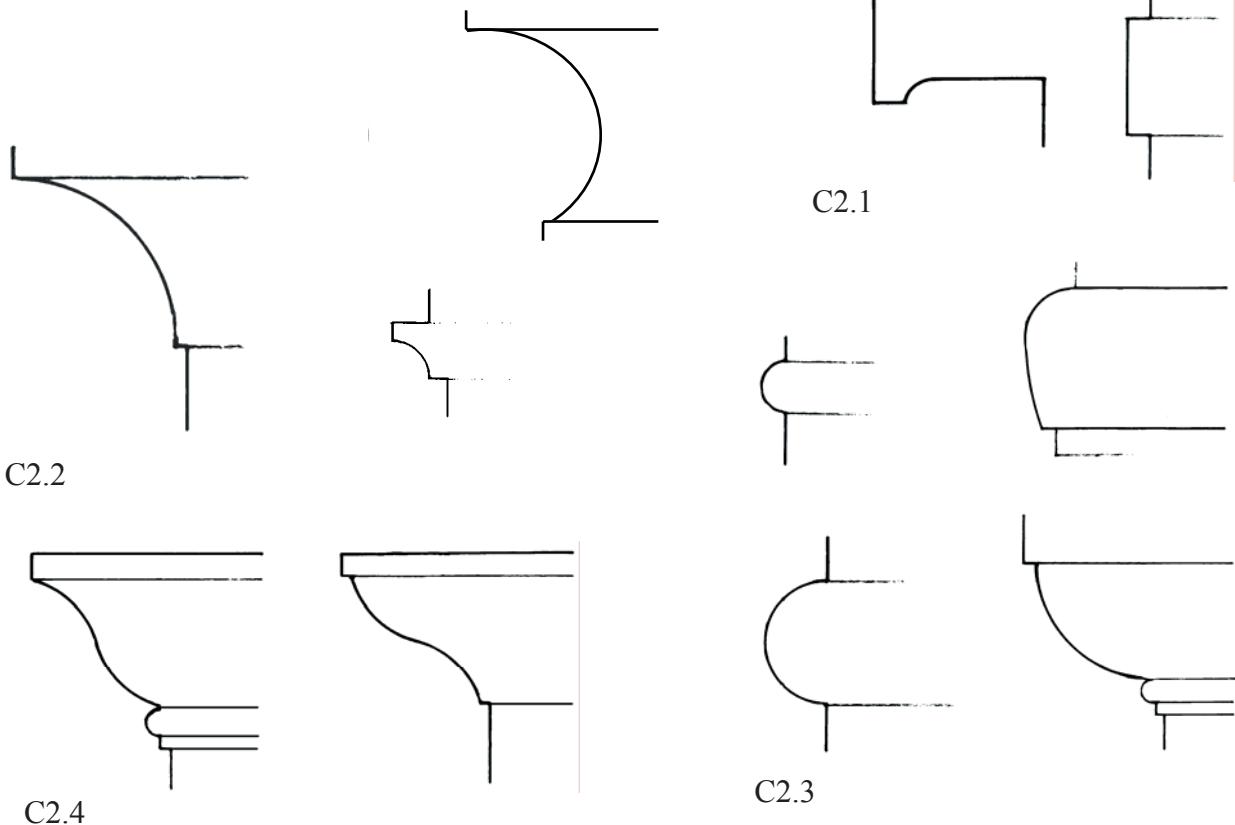
**Dx – materiali e colori delle membrature****D2 – colori delle membrature intonacate**

D2.1- bianco calcare o travertino

D2.2- grigio arenaria o basaltina

D2.3- giallo mattone

D2.4- colore proprio in tono su tono